

**Note:**

These exploded views apply only to version 1.0.  
The version can be determined from the 9th digit of the  
8 number on the nameplate **A** (8.xxx.xxx.x1xxx).

ID	Service parts	S-RS	Description
A-01	6.311.090.001	S	Descaling plug
A-02	6.311.086.001	DT	Lid column B5/10
A-03a	6.205.855.000	S	Electrodes + support B (HW) standard
A-03b	6.305.052.000	S	Electrodes + support B (HW) special
A-04	6.205.850.001	DT	Water tank column B series
A-05	6.016.008.052	RS	High temperature safety switch
A-06a	6.000.205.582	S	Flow boiler B10 (HW) (STD)
A-06b	6.000.205.765	S	Flow boiler B10 (HW) (J)

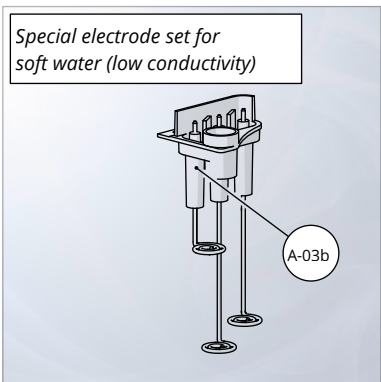
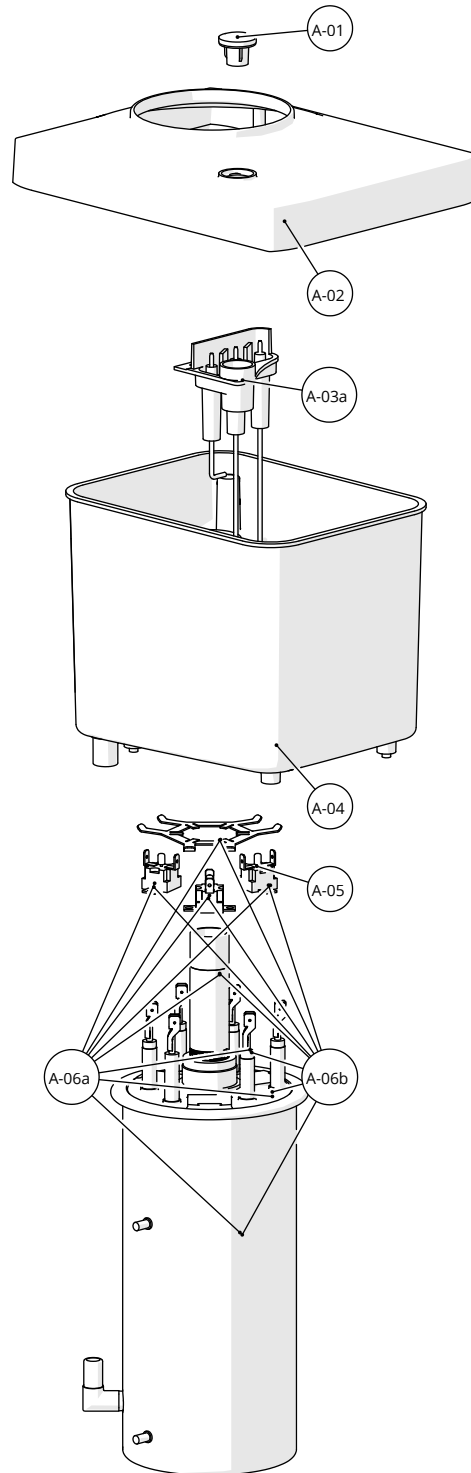

ID	Service parts	S-RS	Description	mm
B-01	6.000.205.111	S	Connection tube 1.5 m	
B-02a	6.016.001.017	RS	Magnetic valve 2.5 l/min (220/240V)	
B-02b	6.016.001.037	RS	Magnetic valve 2.5 l/min (110/127V)	
B-02c	6.016.001.038	RS	Magnetic valve 2.5 l/min (200V)	
B-03	6.001.079.003	S	Tube clamp 15.6 mm	
B-04	6.001.079.006	S	Tube clamp 19 mm	
B-05	6.019.033.014	S	Silicone tube 9.5x3	470
B-06	6.016.024.004	RS	Flow meter	
B-07	6.019.033.014	S	Silicone tube 9.5x3	470
B-08	6.205.853.001	S	Cover waterinlet	
B-09	6.311.113.001	S	Tube 9.5/12.5x2.5	215
B-10	6.019.033.014	S	Silicone tube 9.5x3	90
B-11	6.019.033.012	S	Silicone tube 20x2.5	70
B-12	6.205.826.000	S	Ascending pipe	
B-13	6.205.854.001	S	Sleeve ascending pipe B 5 / B 10	
B-14	6.011.001.060	RS	O-ring 23x4	
B-15	6.017.003.006	S	Magnet swivel arm	
B-16	6.311.098.001	S	Knob swivel arm	
B-17a	6.205.895.000	S	Swivel arm B 10	
B-17b	6.205.896.000	S	Swivel arm WDB 10	
B-18	6.019.033.014	S	Silicone tube 9.5x3	240
B-19	6.006.002.018	S	Tightening plug 10.1x18x18	
B-20	6.229.760.001	S	Nipple	

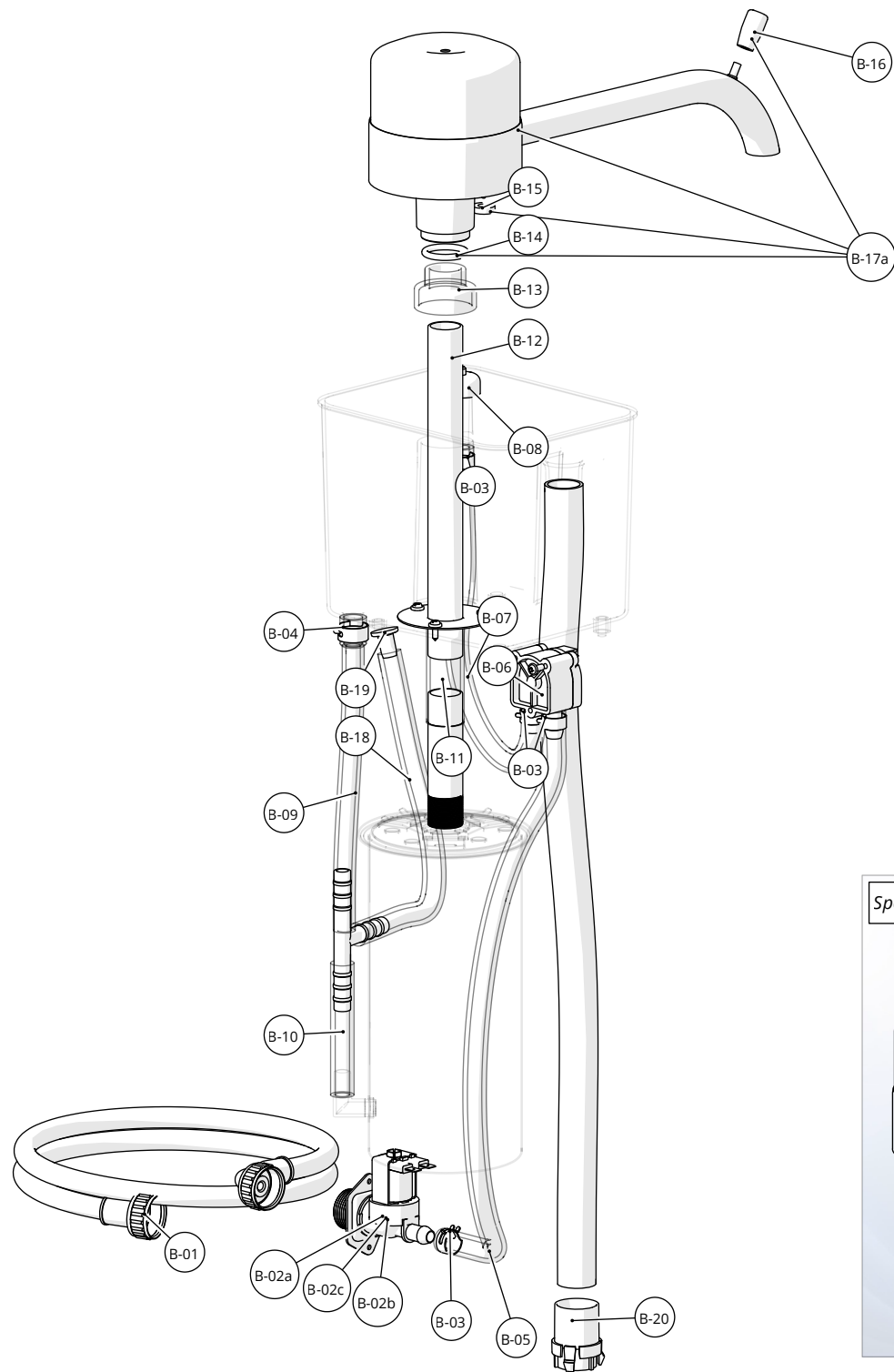

ID	Service parts	S-RS	Description
C-01a	6.006.001.009	S	Cord inlet
C-01b	6.006.001.001	S	Cord inlet (marine)
C-02	6.211.772.000	S	RC combination
C-03a	6.002.001.038	DT	Connection clamp (230V)
C-03b	6.002.019.151	S	Wiring strip (marine)
C-03c	6.002.019.160	DT	Connection clamp (400V3N)
C-04a	6.004.002.068	S	Relay (230V 50Hz)
C-04b	6.004.002.074	S	Relay (120V)
C-04c	6.004.002.075	S	Relay (200V)
C-04d	6.004.002.081	S	Relay (230V 60Hz)
C-05	6.005.012.008	S	Fuse holder
C-06	6.005.011.016	S	Fuse 4A (10 pcs)
C-07a	6.006.005.100	S	Socket (STD)
C-07b	6.006.005.103	S	Socket (CH)
C-07c	6.006.005.104	S	Socket (GB)
C-07d	6.006.005.107	S	Socket (AUS)
C-07e	6.006.005.108	S	Socket (DK)
C-07f	6.006.005.105	S	Socket (NA)
C-08	6.205.865.000	S	Flap for socket left
C-09	6.205.864.000	S	Flap for socket right
C-10	6.401.217.001	S	Adapter switch
C-11	6.004.001.069	RS	Switch
C-12	6.205.859.001	S	Service panel
C-13	6.205.862.001	S	Push buttons
C-14	6.205.860.001	S	Window service panel
C-15	6.205.886.000	S	Reed sensor
C-16	6.006.010.055	S	Cable clip
C-17	6.006.010.078	S	Wire clip 10 mm
C-18	6.006.010.083	S	Cable clip 19 mm

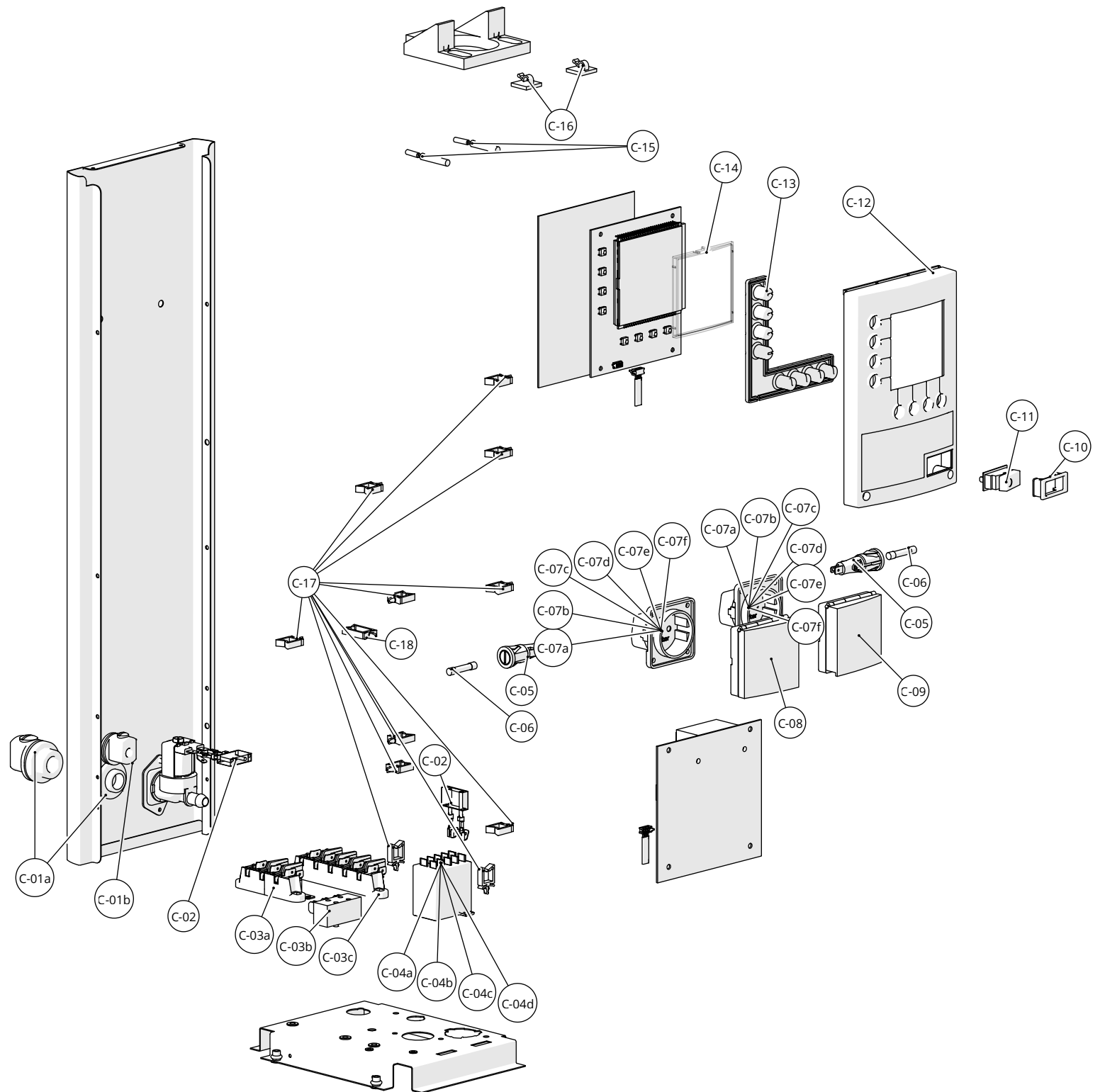

ID	Service parts	S-RS	Description
X1-01	6.205.861.000	RS	Keyboard B (HW)-series
X1-02	6.205.919.000	RS	Flat cable
X1-03a	6.205.873.000	RS	Mainboard B-series (230V)
X1-03b	6.205.955.000	RS	Mainboard B-series (200V)
X1-03c	6.205.957.000	RS	Mainboard B-series (120V)

To the green display X1-01 belong the specific parts X1-02 and X1-03. The parts of X1 and X2 are NOT interchangeable, but it is possible to replace all 3 parts together (X2-01, X2-02 and X2-03) on a machine with a green display. Used till may 2013.

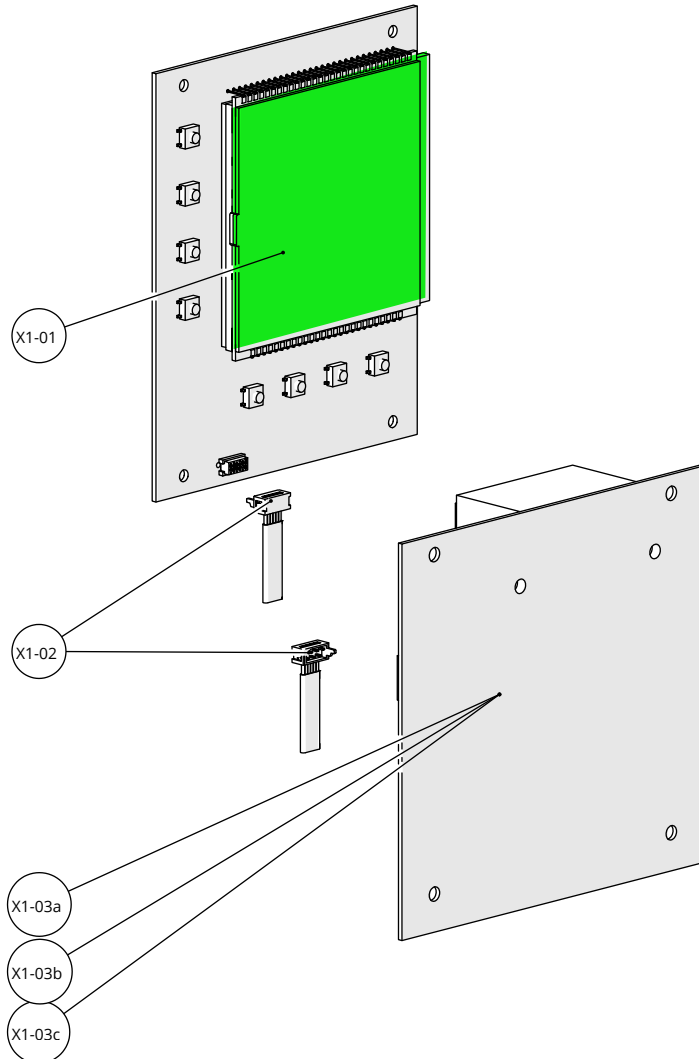

ID	Service parts	S-RS	Description
X2-01	6.305.034.000	RS	Keyboard B (HW)-series
X2-02	6.305.043.000	RS	Flat cable
X2-03a	6.305.035.000	RS	Mainboard B-series (230V)
X2-03b	6.305.037.000	RS	Mainboard B-series (200V)
X2-03c	6.305.039.000	RS	Mainboard B-series (120V)

To the orange display X2-01 belong the specific parts X2-02 and X2-03. The parts of X2 and X1 are NOT interchangeable. Used from june 2013.

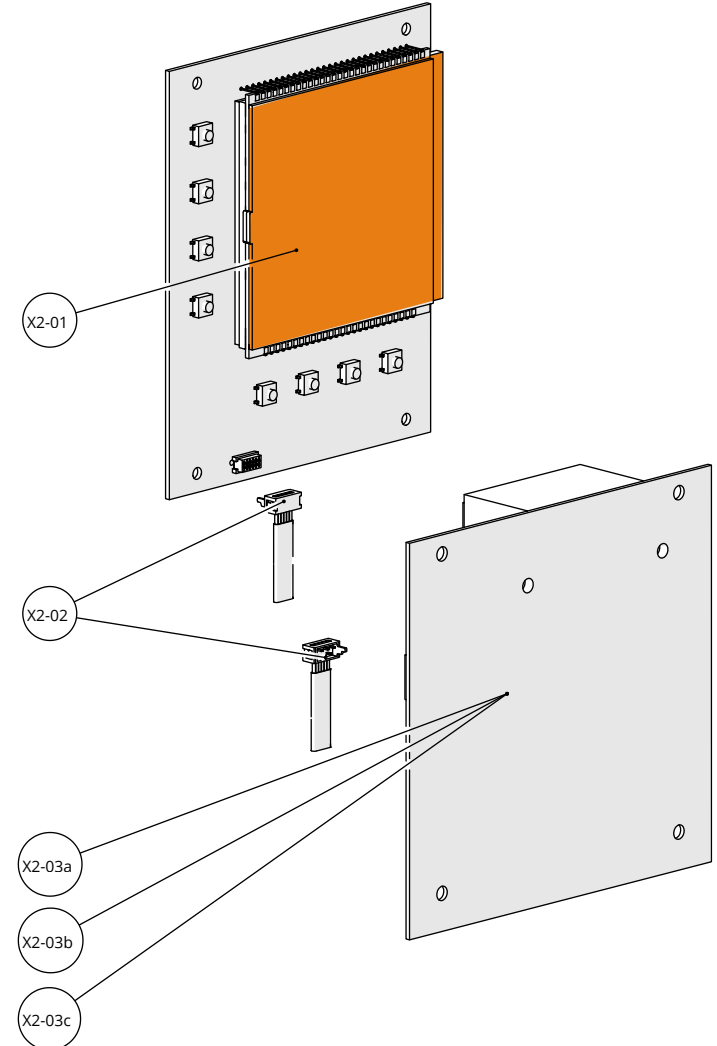

ID	Service parts	S-RS	Description
D-01	6.311.072.001	S	Foot B-series
D-02	6.006.010.084	DT	Cable clip
D-03	6.311.218.001	S	Reed switch safety
D-04	6.206.630.000	S	Reed switch
D-05	6.311.126.001	S	Cam
D-06	6.311.204.001	S	Sealing ring base B-series
D-07	6.311.203.001	S	Cap reed contact switch

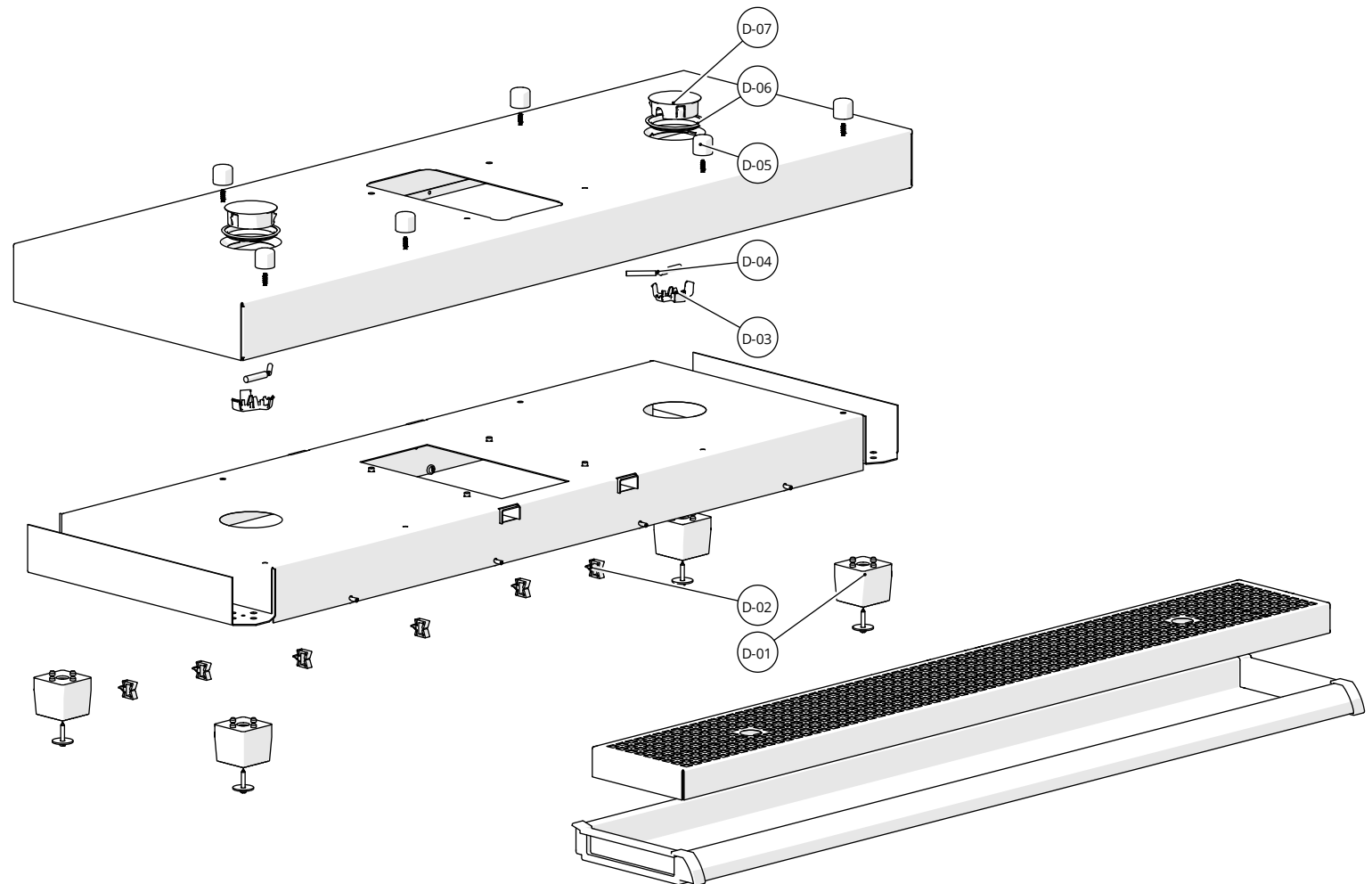

ID	Service parts	S-RS	Description
E-01	6.242.198.001	S	Handle VHG 10
E-02	6.240.145.001	S	Knob lid
E-03	6.006.001.101	S	Cord inlet with pull relief
E-04	6.311.196.001	S	Magnet support
E-05	6.017.003.006	S	Magnet
E-06	6.004.001.081	RS	Switch 230V
E-07	6.240.139.001	S	Cord support grey
E-08	6.011.001.055	RS	O-ring 24x2
E-09	6.242.206.000	RS	PTC element VHG 10
E-10	6.242.190.000	S	Inner urn
E-11	6.240.134.001	S	Cap gauge glass
E-12	6.242.192.001	S	Case for gauge glass VHG 10
E-13	6.242.203.001	S	Strip for gauge glass VHG 10
E-14	6.242.193.001	S	Gauge glass VHG 10
E-15	6.011.001.112	S	O-ring 12x3
E-16	6.015.001.366	S	Upper part for tap
E-17	6.242.191.001	S	Tap handle </td
E-18	6.242.183.001	S	Screw cap tap housing
E-19	6.015.001.027	RS	Spring
E-20	6.015.001.281	S	Lever rod tap
E-21	6.015.001.006	RS	Rubber cup
E-22	6.242.187.001	S	Tap cover VHG 10/20/40
E-23	6.242.181.001	S	Tap housing VHG10/20/40
E-24	6.011.001.057	RS	O-ring 14x3.5

